

Zero Gap Adjustable Weight Bench

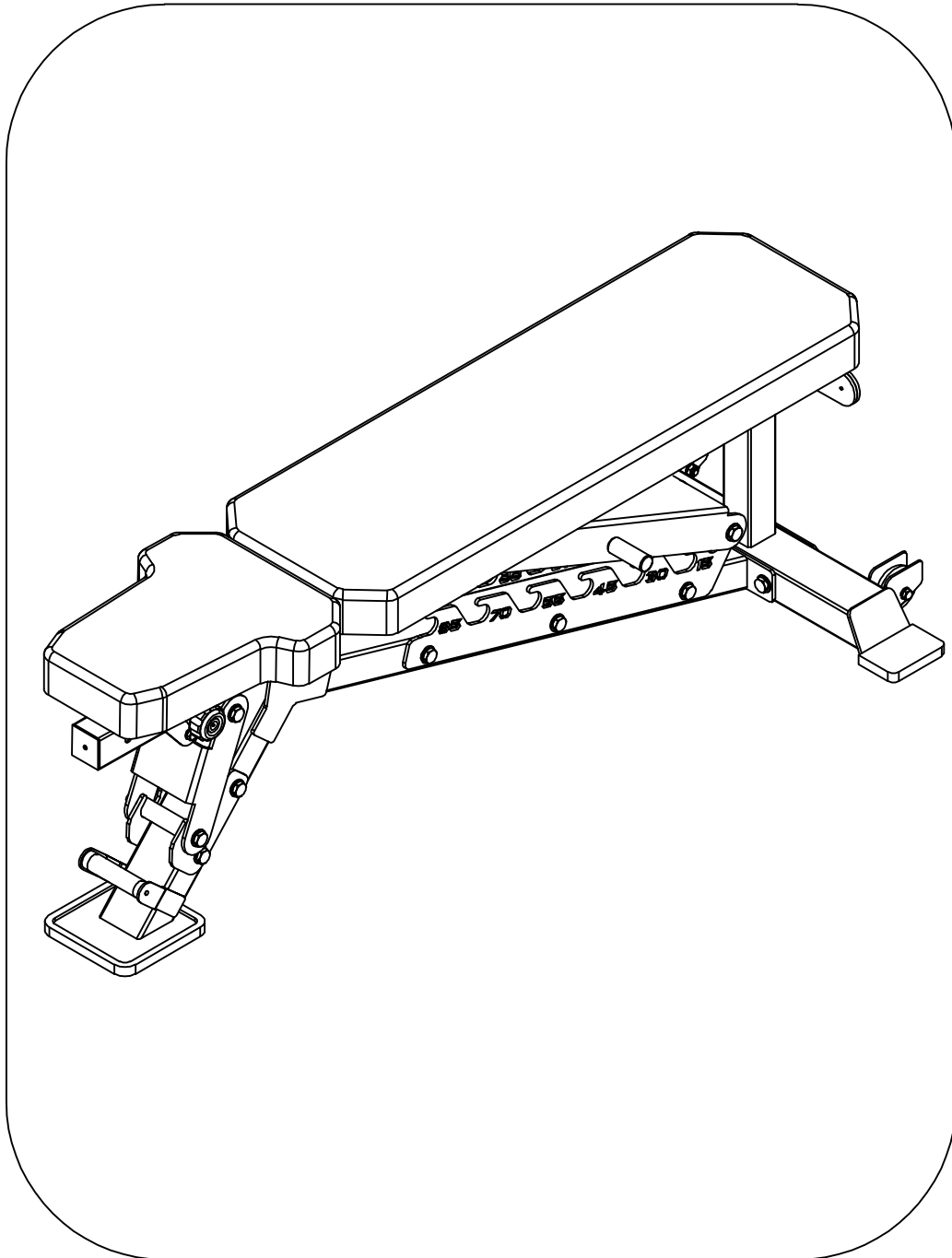

! CAUTION

**Read all precautions
and instructions in this
manual before using this equipment**







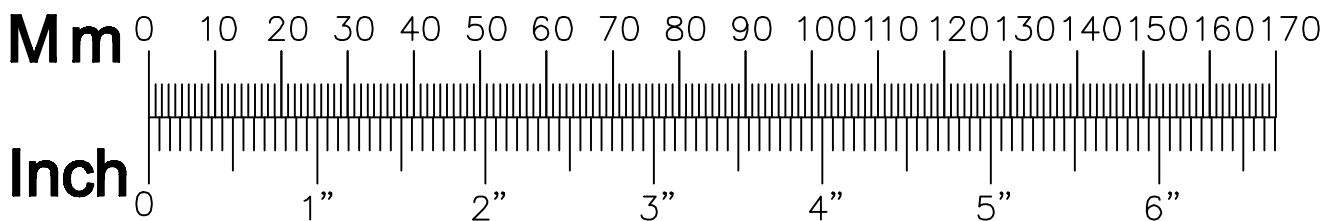

※※※Please read operation manual carefully※※※

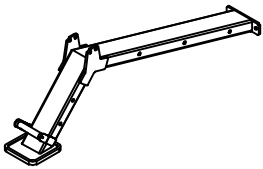
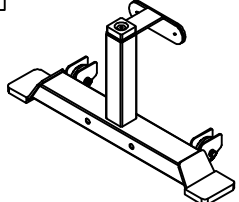
1. Please keep the box and the manual after installing the machine.
2. Check the stability of the bolts regularly.
3. Please install the machine in a commodious place.
4. Put the machine on the level ground, and use a mat to protect the floor.
5. Please consult to your doctor, physician before using any exercise equipments.
6. There are slip proof cover on the nut (little nylon circle on the nut); please tighten them with wrench.
7. Please tighten the screws; otherwise it might be dangerous to use.
8. Please do not alter the machine in any way it might be dangerous to change and mend the machine.
9. Store in the place where is away from moisture, salt (near Pool) high temperature and under sun.
10. For maintenance and cleaning exercise machines Please clean the dirt with detergent scour, using dry rag and clean water (do not use gas, dilution and other chemicals).
11. Do not put your hands in the moving part of the machine when you are doing exercise.

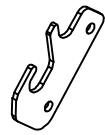
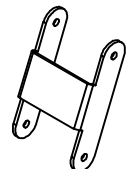
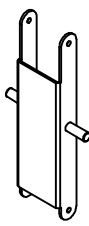
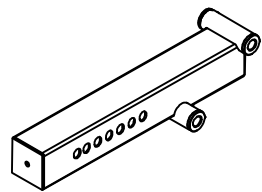
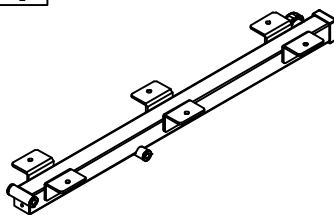
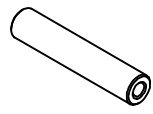
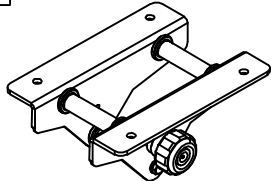
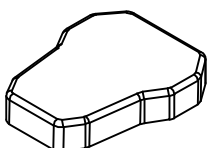
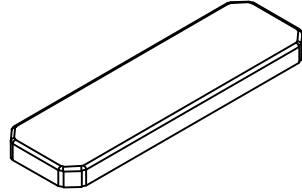
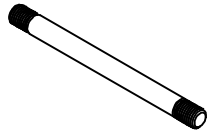
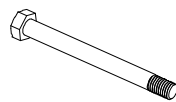
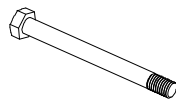
Thank you for choosing our Fitness products, We hope you enjoy using and you get maximum benefit of it.



PART LIST

<p>1</p>  <p align="center">1 PC</p>	<p>2</p>  <p align="center">1 PC</p>	<p>3</p>  <p align="center">1 PC</p>	<p>4</p>  <p align="center">1 PC</p>
<p>5</p>  <p align="center">2 PC</p>	<p>6</p>  <p align="center">1 PC</p>	<p>7</p>  <p align="center">1 PC</p>	<p>8</p>  <p align="center">1 PC</p>
<p>9</p>  <p align="center">1 PC</p>	<p>10</p> <p align="center">Nylon</p>  <p align="center">2 PC</p>	<p>11</p>  <p align="center">1 PC</p>	<p>12</p>  <p align="center">1 PC</p>
<p>13</p>  <p align="center">1 PC</p>	<p>14</p> <p align="center">M12*123 Bolt</p>  <p align="center">2 PC</p>	<p>15</p> <p align="center">M12*100 Bolt</p>  <p align="center">7 PC</p>	<p>16</p> <p align="center">M12*130 Bolt</p>  <p align="center">4 PC</p>
<p>17</p> <p align="center">M8*30 Bolt</p>  <p align="center">10 PC</p>	<p>18</p> <p align="center">M8*16 Bolt</p>  <p align="center">1 PC</p>	<p>19</p> <p align="center">M8 Washer</p>  <p align="center">11 PC</p>	<p>20</p> <p align="center">M12 Washer</p>  <p align="center">26 PC</p>
<p>21</p> <p align="center">M12 Nut</p>  <p align="center">15 PC</p>	<p>22</p>		

Installation Instruction

Step 1

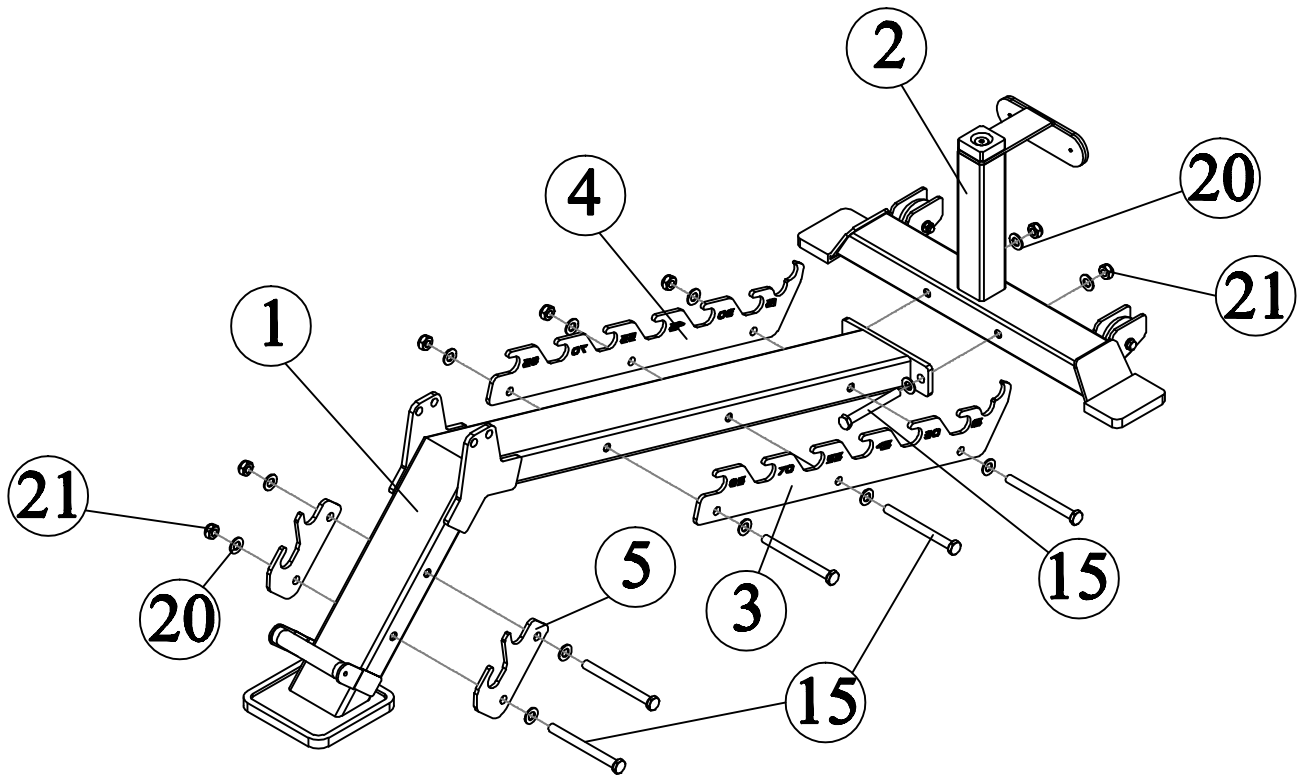

Installation Instruction

Step 2

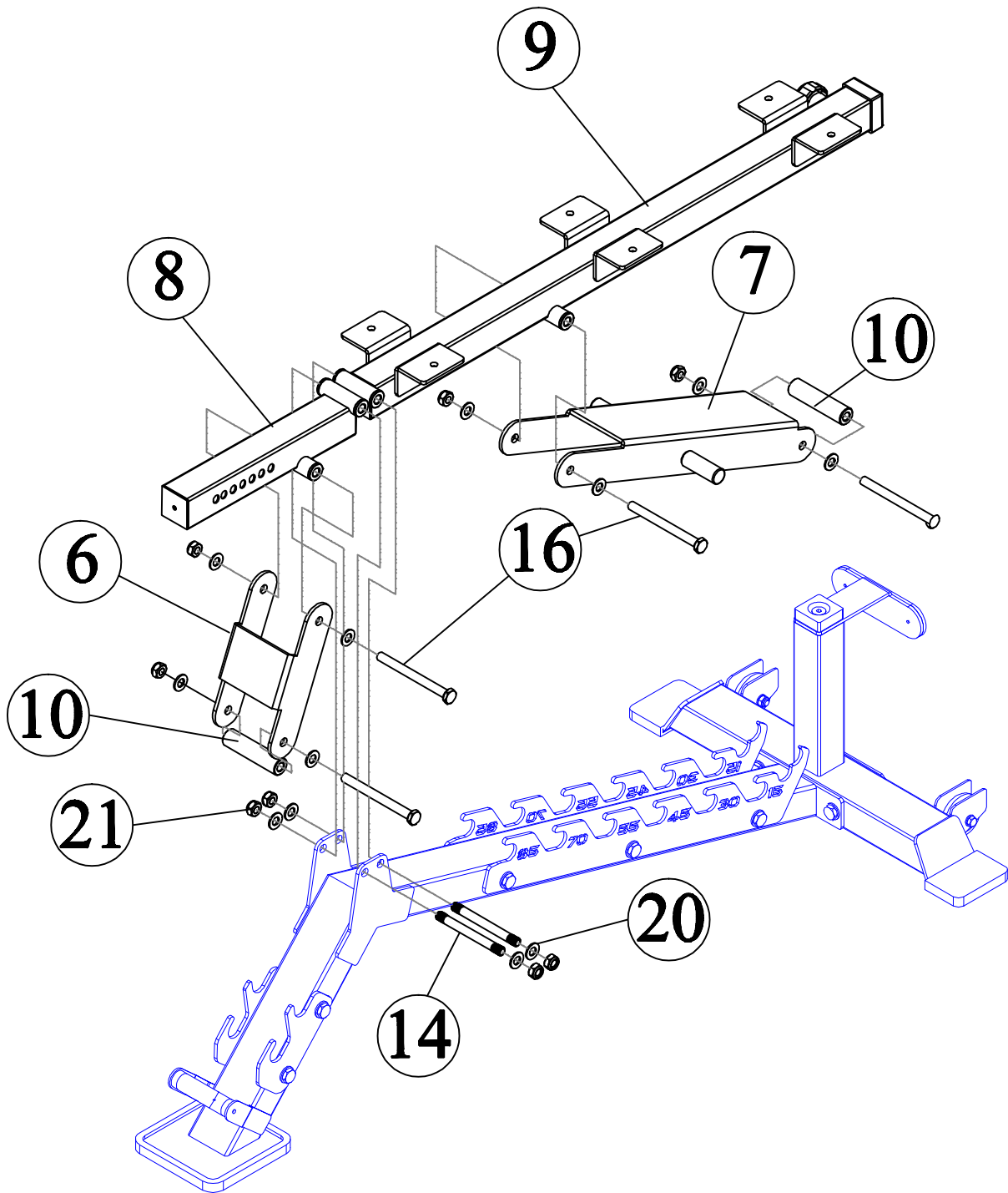

Installation Instruction

Step 3

